

1500F2

15 Bar Pressure Plate Extractor

OPERATING INSTRUCTIONS

February 2015



Fig. 1 - 1500F2 15 Bar Pressure Plate Extractor (shown with PM Hinge attached)

PRODUCT ENHANCEMENT

Soilmoisture has improved the longevity of the interior coating, particularly under high saline or harsh conditions, with our new Water Plus protective coating.

The 1500F1 extractor had only a single coating of polyester. Our new 1500F2 Extractor has the Water + coating which adds two additional layers of protection. The first layer is zinc with phosphate conversion, per ASTM B633, Type 4, SC4. SC4 is for "Very Severe: Exposure to harsh conditions, or subject to frequent exposure to moisture, cleaners, and saline solutions, and damage by denting, scratching, or abrasive wear. F2/Zn 25 microns." The second layer is zinc rich powder primer; and the third layer is a polyester powder coating.

SOILMOISTURE EQUIPMENT CORP.
P.O. Box 30025, Santa Barbara, California 93130 USA
Phone: (805) 964-3525 • Fax: (805) 683-2189
e-mail: sales@soilmoisture.com • Web • www.soilmoisture.com



TABLE OF CONTENTS

Your New 15 Bar Pressure Plate Extractor	Page 03
Warranty	Page 03
Not Liable for Improper Use.....	Page 03
Using Gas Pressure Extractors	Page 04
Acquaint Yourself with the Parts.....	Page 07
Unpacking and Assembly of the Extractor.....	Page 07
Remove Lid.....	Page 07
Mount the Outflow Tube and Plug Bolts	Page 09
Mount the PM Hinge.....	Page 10
Closing and Opening the Lid with the PM Hinge	Page 11
Placement of Triangular Support	Page 12
Installing the Pressure Plate Cells.....	Page 13
Tube Connections to Pressure Plate Cells	Page 14
Pressure Connection	Page 14
Handling and Care of the 15 Bar Ceramic Plates and Extractor Vessel.....	Page 14
Construction of the Pressure Plate Cell.....	Page 14
Preparing Pressure Plate Cells for a Run.....	Page 14
Measuring Diffusion Rates.....	Page 15
Drying the Cells after the Run.....	Page 15
Removal of Evaporation Deposits from Pressure Plate Cells.....	Page 15
Calcium Carbonate Deposits on the Ceramic Surface	Page 15
Deposits in the Pores of the Ceramic	Page 16
Bacterial Action in the Pressure Plate Cell	Page 16
Care of the Extractor Vessel	Page 16
Gas Pressure Source, Pressure Regulation and Laboratory Setup.....	Page 16
Pressure Requirements	Page 16
Existing Pressure Supply.....	Page 16
Initial Setup	Page 17
Pressure Regulation	Page 17
Air Filter use with the Compressor.....	Page 17
Pressure Gauge.....	Page 18
Source of Pressure Regulating Equipment.....	Page 18
Making a Run for Moisture-Retention Studies.....	Page 18
Handling of Soil Samples.....	Page 18
Loading the Extractor.....	Page 18
CAUTION.....	Page 19
Connecting to a Burette.....	Page 19
Turning on the Pressure	Page 19
Removal of Samples.....	Page 19
Action of Gas Pressure on Soil Samples and Uses of Extractor	Page 20
NOTE.....	Page 21
1500F2 Extractor Parts and Accessories	Page 22

THE 1500F2 15 BAR PRESSURE PLATE EXTRACTOR

Unpacking

The 1500F2 Pressure Plate Extractor shipped to you has been thoroughly tested before shipment. When packed, it was in perfect working order. The unit is shipped with the lid of the Pressure Vessel clamped in place on the tank, and all fittings are packed inside the vessel. (Pressure Plate Cells must be ordered separately as they not a standard part of the unit.) Make sure to remove all packing material and tape when you remove the unit from the packing box. Follow the instructions carefully in order to assure long, trouble-free service.

Any damage found upon receipt should be reported immediately to the transport carrier for claim. It is important that you save the shipping container and all evidence to support your claim.

Life Time Warranty

Soilmoisture Equipment Corp. (SEC) warrants all products manufactured by SEC to be free from defects in materials and workmanship under normal use and service for twelve (12) months from the date of invoice subject to the following conditions:

SEC's obligation under this warranty is limited to repairing or replacing (at SEC's option) products which have been returned prepaid to SEC or SEC's agent in the user's country. SEC will return warranted equipment prepaid.

This warranty shall not apply to any SEC products which have been modified, misused, neglected, involved in accidents of nature, or sustained shipping damage. Under no circumstances will SEC reimburse the claimant for costs incurred in removing and/or reinstalling equipment. This warranty, and SEC's obligation thereunder, is in lieu of all other warranties, expressed or implied, including warranties of suitability and fitness for a particular purpose.

Not Liable for Improper Use

SEC is not liable for any damages, actual or inferred, caused by misuse or improper handling of its products. SEC products are designed to be used solely as described in the product operating instructions by a prudent individual under normal conditions in applications intended for each product.

Products may NOT be returned without prior authorization from SEC. A Return Merchandise Authorization (RMA) must be obtained from the factory prior to shipping products to SEC.

Soilmoisture Equipment Corp. is not responsible for any damage, either actual or inferred, for misuse or improper handling of this equipment. The 1500F2 Ceramic Plate Extractor is designed to be used solely as directed by a prudent individual under normal conditions in the applications intended for this instrument.

USING GAS PRESSURE EXTRACTORS

Water relationships are among the most important physical phenomena that affect the use of soils for agricultural or engineering purposes. In the laboratory study of these many physical relationships, as well as the extraction of soil solution for chemical analysis, the Pressure Membrane and Pressure Plate Extractors have become eminently successful research tools.

Many methods, such as compaction, centrifugation, displacement, molecular absorption, and suction have been used to investigate the physical properties of soils as well as to remove soil solution for chemical analysis. In each of these methods the range of application is quite limited. In many instances the methods are cumbersome. In some cases the soil structure is destroyed in the process of making an extraction.

By contrast the Pressure Membrane Extractor and the Pressure Plate Extractors provide a convenient, reliable means of removing soil moisture, under controlled conditions, from soil samples throughout the whole plant growth range, without disturbing the soil structure. The method may be used on disturbed samples or undisturbed soil cores.

Through the application of the Pressure Membrane and Pressure Plate Extractors the characteristic moisture retention curve may be developed for each soil type. The curves, such as shown in Fig. 1, relate the soil suction, at which moisture is held by the soil to its moisture content. This relationship is important in studies of soil moisture movement and of quantity and availability of soil moisture for plant growth.

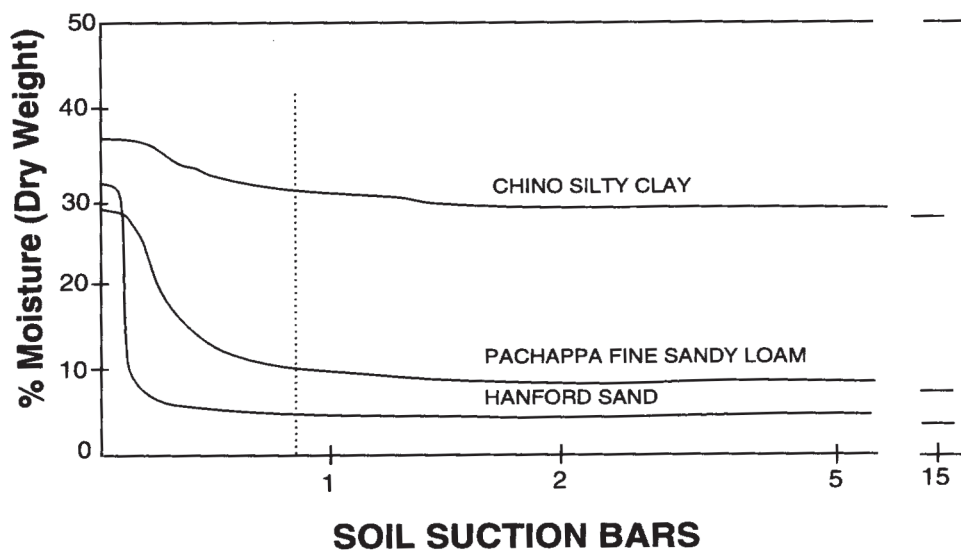

Fig. 2 Moisture Retention Curves shown for three types of soils. The dotted line at .85 bars of soil suction represents the approximate limit of tensiometer readings.

The Pressure Membrane and Pressure Plate Extractors are used in determining the permeability of undisturbed soil cores, and in studies of the hysteresis effect in soils. Soil solution may be extracted in increments at known suction values for chemical analysis. The versatile Pressure Extractors also find application in the calibration of various moisture-measuring equipment and in ultra filtration work, such as the separation of heavy protein molecules from dilute solutions.

The Nature of Gas Pressure Extraction

The principle involved in the operation of the Pressure Membrane and Pressure Plate Extractors is well known. For many years water has been removed from soil by suction wherein a porous ceramic wall serves as a connecting link and at the same time a means of maintaining a pressure difference between the liquid phase of the water in the soil and the water at lower pressure on the opposite side of the wall. The Pressure Membrane and Pressure Plate Extractors are a modification of the suction procedure, where liquid phase water is mobilized across the porous ceramic or membrane using positive pressures. At equilibrium the moisture content is said to be held by an equal but negative force. Thus values of moisture content are expressed related to negative pressures.

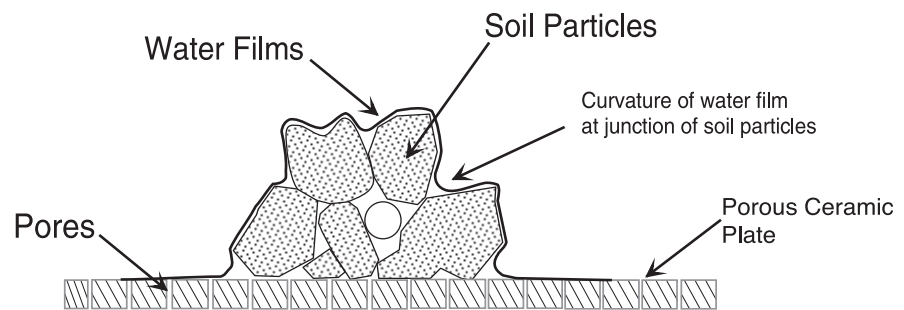

Fig. 3 Magnified view of soil particles on porous ceramic plate

The illustration in Fig. 3 shows a magnified view of soil particles in contact with the porous ceramic plate inside the Pressure Extractor during an extraction run. A wetted porous ceramic plate is backed by a fine mesh screen which also provides a passage way for the extracted solution, and is further sealed by a rubber membrane backing. The soil samples are placed directly onto the ceramic plate and are saturated on the plate. After bolting the Extractor lid onto the Extractor, air pressure may be increased to the value of the test (0.1 to 1500 kPa).

As soon as air pressure inside the chamber is raised above atmospheric pressure, the higher pressure inside the chamber forces excess water through the microscopic pores in the ceramic plate. The high pressure air, however, will not flow through the pores since they are filled with water and the surface tension of the water at the gas-liquid interface at each of the pores supports the pressure much the same as a flexible rubber diaphragm. When the air pressure is increased inside the Extractor the radius of curvature of this

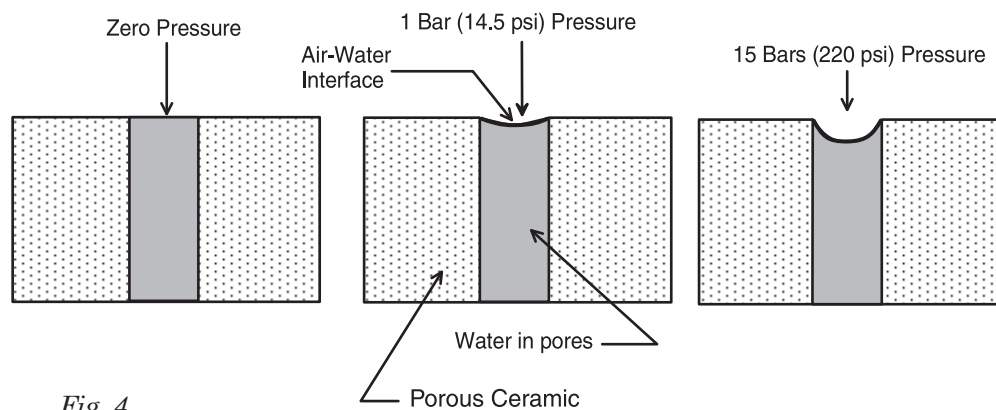

Fig. 4

interface decreases (Fig. 4). However, the water films will not break and let air pass throughout the whole pressure range of the Extractor.

At any given air pressure in the chamber, soil moisture will flow from around each of the soil particles and out through the ceramic plate until such time as the effective curvature of the water films throughout the soil are the same as at the pores in the membrane. When this occurs, an equilibrium is reached and the flow of moisture ceases. When the air pressure in the Extractor is increased, flow of soil moisture from the samples starts again and continues until a new equilibrium is reached.

At equilibrium, there is an exact but opposite relationship between the air pressure (positive force) in the Extractor and the soil suction (negative force). Water content by weight or by volume can be determined for the sample that was at equilibrium with the pressure in the Extractor.

For example, if the air pressure in the Extractor is maintained at 1 atmosphere (15 psi), the soil suction in the samples at equilibrium will be 1 bar. If the air pressure is maintained at 15 atmospheres (220.5 psi) the soil suction at equilibrium will be 15.2 bars, which is the approximate wilting point for all soils. The Pressure Plate Extractors make use of the sample principle of operation.

The principles of operation as defined above, are the same for all our pressure plate extractors (models 1250, 1400, 1405, 1500F2 and 1600F1 Extractors) and the pressure membrane extractors (models 1000 and 1020). The limit of operation for pressure plate extractors is 15 bar (1500 kPa), while the use of cellulose membranes allow pressures up to 100 bar (10,000 kPa). Equilibrium times are more rapidly attained using ceramic plates, as the pore sizes are larger and water may flow at a greater conductance rate.

ACQUAINT YOURSELF WITH THE PARTS

Unpacking and Assembly of the Extractor



Fig. 5 1500F2 Extractor with lid attached

Remove Lid

The 15 Bar Pressure Plate Extractor is shipped with the lid attached to the pressure vessel (Fig. 5). The Triangular Support for the bottom Pressure Plate Cell is packed inside the Extractor. All other items, such as Pressure Plate Cells, Outflow Tube Assemblies, Plug Bolts and Plastic Spacers are packed separately from the Extractor. (See Videos on YouTube for assy and use)

The 15 Bar Pressure Plate Extractor weighs 85 lbs. Carefully lift the Extractor from the packing crate and set it directly on its feet. Remove all packing material and tape from around the Clamping Bolts and over the Outlet Ports in the side of the Extractor. Remove the thread protector cap from the Pressure Inlet Fitting (Fig. 6) before attaching the Connecting Hose.



Fig. 6 - Protector Cap on Pressure Inlet Fitting

Loosen the eight Clamping Bolts around the edge of the unit by turning several turns. It is not necessary to remove the wing nuts from the Clamping Bolts. The Bolts have special rectangular heads that fit into a constraining groove in the bottom of the lower clamping ring. Slip the Bolts out of the slots. (When replacing the Clamping Bolts, always be sure that the heads are properly fitted into the constraining groove - see Fig. 7.) Damage to the bolt head will occur, and can reduce the safety of operating the extractor.



Fig. 7 - Clamping Bolt Heads properly placed into constraining groove. Note the square head fitting into the clamping ring

Remove the Extractor lid by lifting it straight up. If it appears to “stick”, break the seal by forcibly lifting at one edge to break contact between the sealing “O” ring and the lid. Always place the lid with the handle down (Fig. 8). Handle the lid carefully so the under side of the sealing area is not scratched or damaged, as such damage will prevent the unit from sealing properly. The “O” ring seal is left in the groove support of the Pressure Extractor tank.

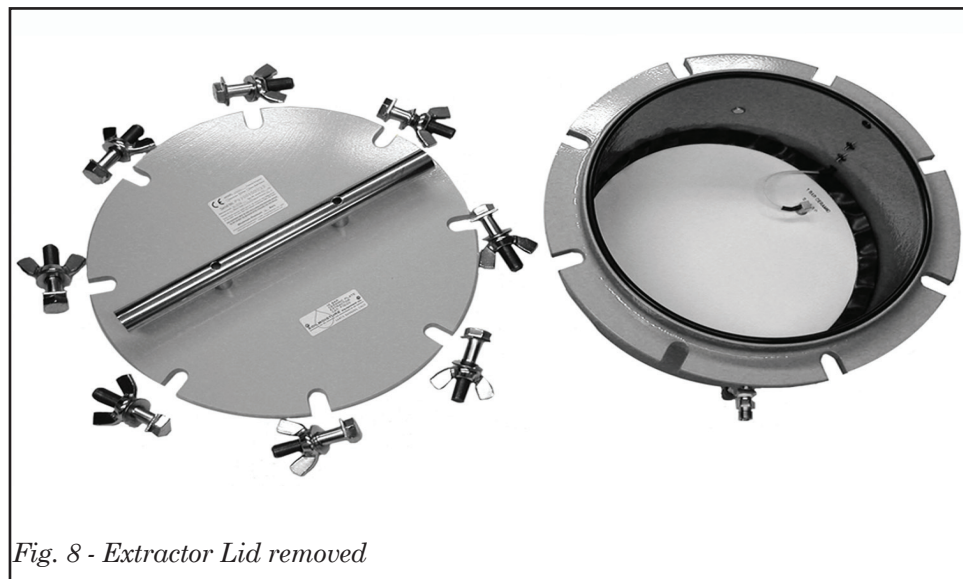

Fig. 8 - Extractor Lid removed

Next remove the the Triangular Support and any packing material.

Mount the Outflow Tube and Plug Bolts

The metal Outflow Tube Fitting is shipped assembled to the other internal connecting tubes. Remove the Rubber Sleeve from the Outflow Tube Fitting (Fig. 9) and screw the Fitting into the Outlet Port in the vessel wall (Fig. 10).

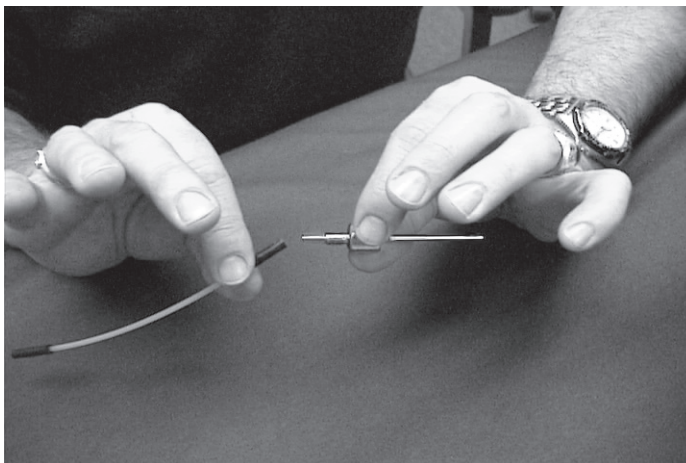

Fig. 9 - Removing the rubber sleeve from the Outflow Tube Assembly



Fig. 10 - Fitting being screwed into the Outlet Port

WARNING

When reassembling the rubber sleeve to the metal Outflow Tube Assembly, be sure the nylon tube inside the rubber tube touches the metal of the Outflow Tube Assembly, otherwise any “gap” can be pinched off by high pressure, shutting off the flow of water.

There are 6 Outlet Ports in the wall of the vessel. 4 Ports are located around the top edge and two others are spaced down the wall of the vessel. Three ports are used when three Pressure Plate Cells are run at the same time, the other three are sealed off using the Plug Bolts (5 Plug Bolts are supplied with the Extractor).

A small Buna “N” rubber “O” Ring is recessed in the head of the Outflow Tube Assembly and Plug Bolt and provides a pressure seal at the Outlet Port. Apply a small amount of Stopcock grease or Vaseline to the exposed portion of the “O” Ring before you initially insert the Outflow Tube Assembly or Plug Bolt. This will lubricate the “O” Ring as it slides against the wall of the vessel when it is screwed into place.

Apply only a small amount of pressure to make the Outlet Port seal. A standard 1/2-inch wrench will fit the Outlet Fittings and Plug Bolts. The fittings should be tightened only enough to bring the outer edge of the Fitting in contact with the flat “spot faced” surface on the pressure vessel wall. This will provide the proper compression on the “O” Ring to make the seal. Further tightening will damage the Fitting and shorten the life of the “O” Ring seal.

Mount the PM Hinge

The PM Hinge provides a convenient means to open and close the Pressure Extractor. Due to the weight of the steel plate used in the manufacture of the Pressure Extractor lid, the PM Hinge allows workers to easily open and close the Extractor to load and remove samples.

The PM Hinge (1080G1) comes with an Adapter Plate (1081). This Plate fits on top of the Extractor lid under the top clamp of the PM Hinge and provides the proper spacing to match the clamp height (Fig. 11).

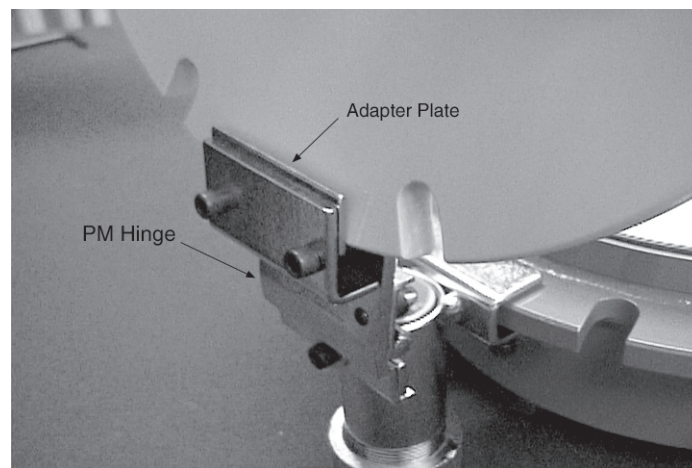

Fig. 11 -PM Hinge with Adapter Plate attached to 1500 Extractor

Mounting the PM Hinge at the back of the 15 Bar Pressure Plate Extractor is accomplished in two simple steps:

Step 1: Remove the top plate of the Extractor. Remove any packing tape from the PM Hinge which is shipped completely assembled and ready to install. Loosen the socket head mounting screws on the lower mounting bracket of the hinge. Slip the bracket over the edge of the bottom part of the Extractor. The lower mounting bracket is centered in the section between the two bolt slots adjacent to the Outlet Stem of the Extractor. Next, securely tighten the mounting screws using the wrench provided.

The ends of the screws enter the same groove in the bottom part of the Extractor that is provided to constrain the heads of the Extractor Clamping Bolts.

The adjustable cap can now be adjusted either up or down to match the leg height so that the Extractor sits level on the lab bench.

Step 2: Holding the Extractor Lid vertically, slip the Lid into the top mounting bracket of the PM Hinge (see Fig. 13). Orient the Extractor Lid so that the handle is parallel to the lab bench and the pressure fitting next to the Hinge. Center the mounting bracket between two bolt slots. Lightly tighten the two mounting screws. The Extractor lid may now be lowered and the PM Hinge will counter its weight. After the Lid is lowered, you might want to make slight adjustments to the Lid's orientation in respect to the lower part of the Extractor for proper alignment. Once properly aligned, the mounting screws for the Extractor lid may now be securely tightened. Both the clamping screws and the wrench are made of heat treated steel and they will not be damaged by secure tightening. A drop of oil occasionally on the moving parts will help its action and avoid squeaks.



Fig. 12



Fig 13

Closing and Opening the Lid with the PM Hinge

To use the PM Hinge you must turn the two wing nuts on either side of the Hinge to compress the counterbalancing spring in the Hinge when the lid is closed.

Follow these instructions carefully:

1. First apply a thin coat of heavy grease (wheel bearing grease) on the underside of each wing nut and the top of each washer.
2. Close the lid and insert the first two Clamping Bolt Assemblies, one on either side of the Hinge and immediately adjacent to it.
3. Tighten the first wing nut until it is snug and then repeat with the other one.
4. Work back and forth tightening first one and then the other until the lid is down against the top of the Extractor vessel.
5. Insert the six remaining Clamping Bolt Assemblies
6. Tighten all wing nuts until they are firm.

When the Extractor is opened after a run, the process is reversed:

1. First loosen and remove all Clamping Bolt Assemblies, except the two on either side of the Hinge.
2. Loosen one of the remaining Bolts about 1/8 turn, then the other about 1/8 turn.
3. Work back and forth slightly loosening first one and then the other Bolt until they turn easily (about 2-3 full turns) and can be removed.

Placement of Triangular Support in Bottom of Tank

The Triangular Support must be placed on the bottom of the Extractor vessel before any Pressure Plate Cells are installed (Fig. 14).

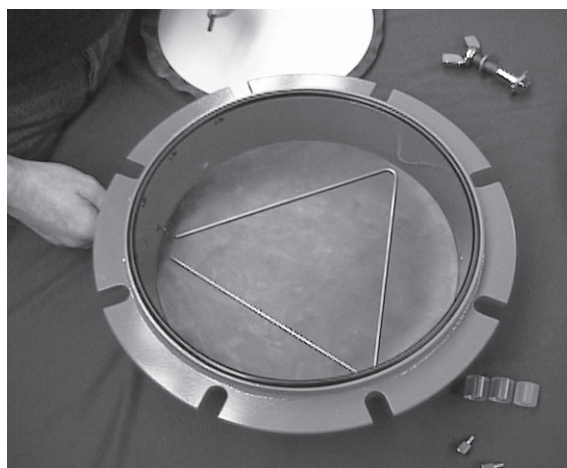

Fig. 14 - Triangular Support placed in bottom of Extractor prevents plate breakage

The purpose of the Triangular Support is to keep the lower Ceramic Plate Cell off the bottom of the Extractor. If the Support is not used, a seal can occur between the outer edge of the rubber backing on the Pressure Plate Cell and the flat bottom of the Extractor. Then when air pressure is applied, a large pressure differential will develop between the top and bottom of the ceramic plate and break it.

Remember: Always make sure that the Triangular Support is placed in the bottom of the Extractor before the Pressure Plate Cells are installed.

Installing the Pressure Plate Cells

Place the first Pressure Plate Cell directly on the Triangular Support on the bottom of the Extractor. Connect this Cell through the lowest Outlet Port (Fig. 15).

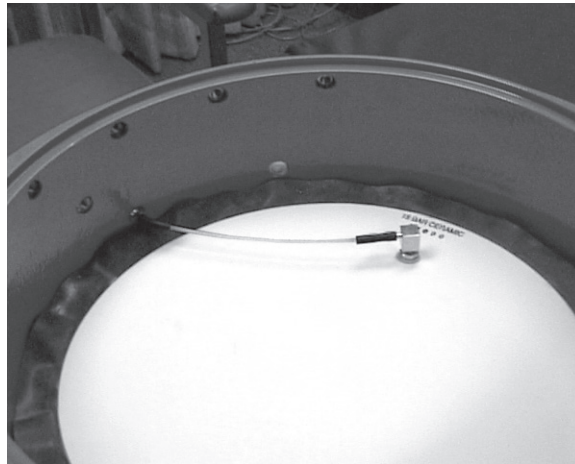

Fig. 15 - First cell placed on top of triangular support connected to outlet port

Place the second Pressure Plate Cell on the three Plastic Spacers that are set near the outer edge of the first Pressure Plate Cell at approximately 120 degrees from each other (Fig. 16). Connect this Cell through the middle Outlet Port.

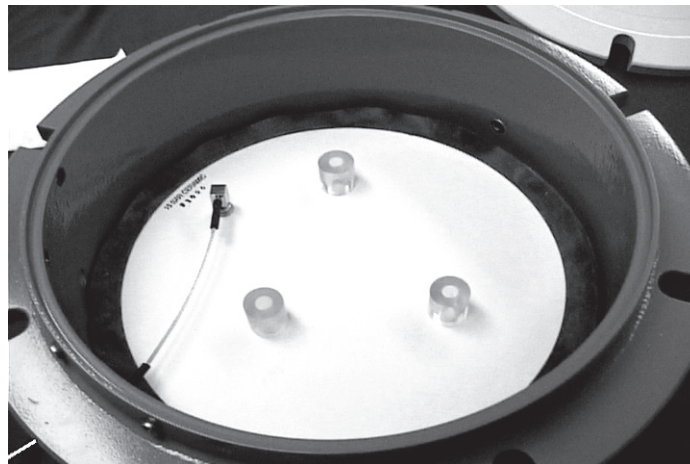

Fig. 16 - Spacers sit on first plate before placing the second plate into the Extractor

Use the flexible outer edge of the Rubber Diaphragm to lift the Pressure Plate Cells in and out of the Extractor.

Tube Connections to Pressure Plate Cells

In general, the Pressure Plate Cells have a tendency to be convex. For this reason, you must support the Plate by placing your fingers directly behind the Outlet Stem when you connect the Rubber Sleeve.

When you make the internal tube connections at the Cell and the Outlet Port, make very sure that the hard Nylon tubing runs through the sleeve and up to or into the metal connecting parts. The Nylon tubing will withstand the high extraction pressures without collapsing if it is properly installed as explained above. The Rubber Sleeves are not meant to withstand the high pressure. Properly connecting the Nylon tubing will ensure an accurate equilibrium reading.

If the tubing collapses because the connections were not properly made, an inaccurate equilibrium reading will result. This malfunction becomes apparent only at the end of the run when the Outflow Tube emits a rush of air when the pressure in the chamber is released.

Pressure Connection

The single Pressure Inlet to the Extractor is an Adapter (1500-005), located opposite the Outlet Ports on the wall of the vessel a small distance from the bottom. Couple a standard Connecting Hose (0775L60), directly to this fitting. Thread size of the Pressure Fitting is 9/16-18. To make the pressure seal at the hose connection, press the round "nose" of the brass stem inside the Hose Nut against the recessed conical surface of the 1500-005 Adapter. This is a very effective metal to metal seal. (The screw threads on the fitting and nut serve as a means to hold the parts in contact. The threads themselves do not make the seal.)

HANDLING AND CARE OF THE 15 BAR PRESSURE PLATE CELLS AND EXTRACTOR VESSEL

Construction of the Pressure Plate Cell

Each Pressure Plate Cell consists of a 15 Bar ceramic plate approximately 10-1/4" in diameter that is sealed on one side by a thin Butyl diaphragm. An internal screen keeps the diaphragm from close contact with the plate and provides a passage for flow of water. An outlet stem running through the ceramic plate connects this passageway to the outflow tube assembly.

The 15 Bar ceramic is quite strong. However, to avoid damage to the Pressure Plate Cells, do not load them mechanically and/or subject them to sharp blows.

Preparing Pressure Plate Cells for a Run

Before making a run, check the Pressure Plate Cells to make sure they have not been damaged in shipment and to familiarize yourself with their characteristics. Prior to shipment each cell is tested for water outflow rate and air diffusion rate, and a permanent record is kept for each cell.

Let an excess of water stand on the surface of the Pressure Plate Cells for several hours to thoroughly wet the plate. Approximately 150 ml of water is required to fill the pores of each plate.

Next, mount one or more of the wetted plates in the Extractor and make the outflow connections. Carefully add water on the surface of each Cell so it is completely covered to the maximum depth permitted by the outer edge of the Butyl diaphragm.

Close the Extractor and build up the pressure to 15 Bars (220 psi). As the pressure builds inside the Extractor there will be a rush of air from the Outflow Tubes. This rush of air is caused by the diaphragm and screen collapsing under the pressure in the Extractor and the resulting reduction of the Cell's internal volume. If the internal outflow tubing connections are "tight" and the Cell has not been cracked or damaged, the airflow will stop after several minutes and there will be a steady flow of water.

Small bubbles of air will come out in the flow of water at reasonably regular intervals. This air is slowly diffusing through the ceramic plate. The outflow rate in ml/min should be measured soon after flow starts while the entire surface of the ceramic is covered with water.

After all of the water on the Cell is conducted through the plate, the flow of water will stop. The slowly diffusing air will gradually conduct small amounts of water surrounding the internal screen to the outside.

Measuring Diffusion Rates

To measure the rate of diffusion, connect a short length of rubber tubing to the outflow tube and insert the end under an inverted graduate that has been filled with water. The flow rate of air should be less than 1/10 ml of air, at atmospheric pressure, per minute with the Extractor pressure at 220 psi. If the flow rate of air is appreciably higher than this it indicates either there is a leak in the tubing connection, or the Cell is cracked or not sealed properly.

Drying the Cell after the Run

When a Pressure Cell is to be dried for storage after a run, it is very important to keep evaporation deposits on the surface to a minimum. To do this, cover the surface of the ceramic plate with a thin layer of fine dry soil and allow it to set for several days until dry. After it is dry, remove the soil and store the Cell. This procedure forms the evaporation deposits on the soil particles rather than on the surface of the Cell.

After a period of time, if the flow rate of a Cell drops due to deposits, they should be replaced.

Removal of Evaporation Deposits from Pressure Plate Cells

Remove Calcium Carbonate deposits on the surface of the ceramic by carefully sanding the surface with 200 to 400 grade wet or dry carborundum sand paper.

Deposits in the Pores of the Ceramic

Remove deposits in the pores of the ceramic by flushing a 10% solution of Hydrochloric acid through the Pressure Plate Cell under pressure in the Extractor. Follow this with a similar flush of distilled or deionized water.

Bacterial Action in the Pressure Plate Cell

The internal screen is made of Polypropylene to minimize this condition. If there is a problem with bacterial action, the Cell can be flushed under pressure periodically with a solution of Copper Sulfate or Mercuric Chloride using the same procedure as above.

The Extractor vessel and top are ruggedly constructed and well plated for protection. They should require little attention.

Care of the Extractor Vessel

Handle the Extractor carefully to protect the “O” Ring Seal area from damage. Keep soil particles clear of the “O” ring and the seat in the wall of the vessel.

Periodically wash the Extractor with a mild, soapy water and rinse with deionized or distilled water. Towel dry and store with lid removed to prevent moisture build up inside the vessel during storage.

The vessel is coated on the inside with an asphalt-based paint called “Gila Coat”, which is manufactured by the W. P. Fuller Paint Company. If rust develops inside the vessel, it can be re-coated with this or a comparable product.

GAS PRESSURE SOURCE, PRESSURE REGULATION, LABORATORY SETUP

Pressure Requirements

The 15 Bar Pressure Plate Extractor requires a source of regulated gas pressure of 220 psi or more in order to make moisture extractions from soil samples from 10 kPa to 1500 kPa through the wilting point (15 Bars or 1500 kPa).

Existing Pressure Supply

If your laboratory already has a regulated pressure source for pressure membrane equipment it can be used for the 15 Bar Pressure Plate Extractor. Pressure connection for the 15 Bar Pressure Plate Extractor can be made to the same line that supplies air to the “extraction chamber” on the pressure membrane extractor. Appropriate shutoff and vent valves must be provided for the new Extractor.

Initial Setup

If an initial setup is made for the 15 Bar Pressure Plate Extractor, either a compressor or compressed gas in tanks can be used as the pressure source.

The compressor (0505V1106 or 0505V2206) provides a convenient, low cost pressure source for all gas pressure extractors and can be used as a pressure source for 1500F2 Pressure Plate Extractor.

Compressed nitrogen or air (2000 psi/13,794 kPa) in tanks can be used particularly where the Extractor is operated on a limited basis. When tank gas is used, make sure that all piping is leak-free. A small leak can waste a large volume of gas over a run period.

The internal volume of the 15 Bar Pressure Plate Extractor is approximately 1/4 cu. ft. If continuous extractions are made at the 15 Bar level, an air compressor is the best pressure source.

Pressure Regulation

The type of pressure source to be used and the accuracy required for the studies to be conducted determine the type of pressure regulator to be used.

Accuracy of regulation depends on the construction of the regulator and variations in the pressure from the source of supply. When using Regulators that are suitable for use with this equipment, the expected variations in pressure will be reflected in the regulated pressure in the ratio of about 1/12 to 1/25. In other words, variations in pressure from a compressed air source of 25 psi will change the regulated pressure by 1 to 2 psi depending on the make of the regulator.

Where extreme accuracy is needed, use “double regulation” to eliminate this variation. This means putting two regulators in series. The first regulator is set at a higher pressure than the second in order to supply reasonable constant pressure to the second regulator. Pressure from the second regulator will be very constant with source pressure variations reduced at least 1/100.

For routine determinations of the 15 Bar percentage a setup using a single high-pressure regulator is adequate. At lower pressures a more sensitive regulator should be used.

To provide good regulation in the whole range from 0 through 15 Bars, two regulators should be used. Use the high-pressure regulator for the high range and fit it with a simple valve arrangement to allow the pressure to be diverted to the low-pressure regulator for work in the low range. This makes use of the principle of “double regulation” in the low-pressure range.

If compressed gas in tanks is the pressure source use the 0767P0300L05 Regulator for best results.

Air Filter Use with the Compressor

When a compressor is used as the pressure source an air filter should be installed ahead of the regulators. The filter helps keep small dirt particles out of the regulators. When the regulated pressure tends to drift from its set value it is usually due to an improperly seated valve in the regulator. Most often this is caused by an accumulation of dirt on the valve seat.

Pressure Gauge

A precision pressure gauge is required for accurate readout of the regulated pressure. Soilmoisture's Test Gauge, 0780P0300, is a 6-inch precision gauge, with 1/4 of 1% accuracy well suited for use with the 15 Bar Extractor.

Pressure control equipment and manifold fittings called out can be obtained through local dealers or SEC's sales dept.

Source of Pressure Regulating Equipment

Complete manifolds suitable for use with this equipment, assembled and tested, can be obtained from Soilmoisture Equipment Corp. Please see our catalog or call us for further details.

MAKING A RUN FOR MOISTURE-RETENTION STUDIES

Handling of Soil Samples

Soil samples must be handled properly for accurate, consistent results. Refer to the procedures in the U.S. Department of Agriculture Handbook No. 60, "Diagnosis and Improvement of Saline and Alkali Soils". This handbook covers detailed procedures for the 1/10, 1/3, and 15 Bar percentage determinations and the development of moisture-retention curves.

When moisture equilibrium studies are being run, keep sample heights small so the time to reach equilibrium is reasonable. The time required to reach equilibrium varies according to the square of the sample height. For example, a soil sample 2-cm high will require four times as long to reach equilibrium as a 1-cm high sample. Soil sample heights should be limited to 1-cm when possible. Our Soil Sample Retaining Rings (1093F1), which will hold a 25 gm sample and are 1 cm high by 5-1/2 cm in diameter, are ideal for retaining prepared samples.

Before placing samples on the Pressure Plate Cell, connect the Nylon Tube and Rubber Sleeve to the Outlet Stem on the Cell.

Prepare duplicate 25 gm samples that have been passed through a 2-mm round-hole sieve for each soil type to be run. Place soil sample retaining rings on the Cell. Each Pressure Plate Cell will accommodate 12 samples that are retained in these rings.

Dump the entire soil sample from each container into a ring to avoid particle-size segregation. Pouring out part of the sample makes a non-representative sample. Level the samples in the rings, cover them with squares of waxed paper, and allow them to stand at least 16 hours with an excess of water on the plate.

Loading the Extractor

To load the Extractor, first make sure the Triangular Support is placed in the bottom of the vessel. When the samples are ready, remove the excess water from the Cells with a pipette or syringe. Mount the Cells in the Extractor and connect the Outflow Tubes. Use the plastic spacers to separate the Ceramic Plate Cells. Close all unused Outlet Ports with the Plug Bolts that are provided.

Make sure the "O" Ring is in place, mount the lid, and screw down the Clamping Bolts.

CAUTION

Be sure that the heads of the Clamping Bolts are properly seated as shown in Fig. 04 in the constraining groove. Improper placement could cause damage to the bolts and a proper seal may not be made.

Connection to a Burette

Connect each Outflow Tube to the tip of a burette with a piece of small diameter tubing to determine when equilibrium has been reached. Gas diffusing through the ceramic plate passes continuously, via small bubbles, through this small outflow tube and transports the extracted liquid to the burette. Read the burette periodically to follow the approach to equilibrium. After equilibrium is attained, if the pressure in the Extractor is maintained constant no measurable change in the burette reading will be seen for many hours or days.

Turning on the Pressure

Build up the pressure in the Extractor to the equilibrium value slowly. This procedure will allow you to make the most accurate setting on the equilibrium value.

As the pressure builds up inside the Extractor, there will be a rush of air from the Outflow Tubes. This rush of air is caused by the diaphragm and screen collapsing under the pressure in the Extractor and the resulting reduction of the Cell's internal volume. If the run is for determination of the 15 Bar percentage, set the pressure in the Extractor at 15 Bars or 220 psi.

If the Extractor pressure is set immediately at 220 psi when the PM compressor is used as an air source, the compressor tank pressure could be reduced below the required level. This would happen because the volume of the Extractor is larger than the volume of air in the storage tank. If this occurs, turn the On-Off switch to OFF and then to ON to restart a 5-minute cycle. A single run cycle on the compressor will build the pressure above the pressure value required.

Removal of Samples

Samples may be removed when readings on the outflow burettes indicate flow has stopped and equilibrium has been attained. Most soils will approach hydraulic equilibrium within 18 to 20 hours.

At the close of a run, remove or pinch off the external tubes running from the outflow tube assemblies to prevent possible back flow of water when the pressure in the Extractor is released.

Remove the Clamping Bolts and lid immediately after you have shut off the Extractor and exhausted the pressure. In order to avoid moisture content changes; transfer the samples to moisture boxes as quickly as possible.

Action of Gas Pressure on Soil Samples and Uses of Extractor

As soon as air pressure inside the vessel is raised above atmospheric pressure, the higher pressure inside the vessel forces excess water through the microscopic pores in the 15 Bar ceramic plates. The high-pressure air will not flow through the pores since they are filled with water. Also, the surface tension of the water at the gas-liquid interface at the pores supports the pressure like a flexible rubber diaphragm. When the air pressure is increased inside the Extractor, the radius of curvature of the gas-liquid interface decreases. The water films will not break, and they let air pass throughout the whole pressure range of the Extractor from 0 to 15 Bars.

At any given air pressure in the chamber, soil moisture will flow from around each of the soil particles and out through the ceramic plate until the effective curvature of the water films throughout the soil are the same as at the pores in the ceramic plate. When this occurs, an equilibrium is reached and the flow of moisture stops.

When air pressure in the Extractor is increased, flow of soil moisture from the samples starts again and continues until a new equilibrium is reached. At equilibrium there is an exact relationship between the air pressure in the Extractor and the soil suction (the moisture content) in the samples. For example, if the air pressure in the Extractor is maintained at 1 Bar or atmosphere (15 psi), the soil suction in the samples at equilibrium will be at 1 Bar. If the air pressure is maintained at 15 Bars or (220 psi) the soil suction at equilibrium will be at 15 Bars, which is the approximate wilting point for all soils.

The 15 Bar Pressure Plate Extractor can be used for all types of studies involving the moisture relationships in soils. All types of soil samples may be used with the exception of fine clay soils that experience considerable shrinkage as moisture is removed. This type of soil will shrink away from the ceramic plate in 15 Bar extractions, and the reduced flow area will not permit the sample to reach equilibrium.

The 15 Bar Pressure Plate Extractor provides the latest dimension for ease of handling and efficiency of operation in moisture equilibrium studies throughout the whole plant growth range from 0 to 15 Bars.

A complete stock of accessories and replacement parts for the 15 Bar Pressure Plate Extractor is maintained in our warehouse for prompt delivery. Details and prices are shown in our current catalog.

NOTE

Always use the Right Angle Outflow Tube Adapter (1055K1), when you stack two or more Pressure Plate Cells in the Extractor.

When you push the stem on the Adapter into the hole in the Rubber Connecting Sleeve, be sure the Nylon Connecting Tube is butted up to the stem. The Rubber Sleeve is used only to make a seal and is not meant to support the high extraction pressures.

The hole in the Right Angle Adapter has an internal “O” Ring that makes a pressure seal when it is slipped over the outlet stem from the Pressure Plate Cell. This Adapter is very easy to connect and disconnect from the Pressure Plate Cells when the Cells are loaded/unloaded from the Extractor. The Adapter also eliminates possible kinking of the Outflow Tube Assembly. This prevents pinching off of the Outflow Tube, which can result in erroneous equilibrium values and possible damage to the Pressure Plate Cells.

NOTE

Do NOT use the 15 Bar Pressure Plate Cells, supplied with this unit for determination of the 1/10 Bar and 1/3 Bar moisture percentages of soils. Due to the very small pore size of the 15 Bar Ceramic, the flow rate through the ceramic plate is very low at pressure differentials across the plate of 1/10 Bar (1.5 psi) and 1/3 Bar (5 psi). The result would be extremely long equilibrium times, and most likely higher than actual equilibrium moisture content values.

Instead, use 1 Bar Ceramic Plate Cells (0675B01M3) for measurement of 1/10 Bar and 1/3 Bar moisture percentages and all other work in the 0 to 1 Bar range. These Pressure Plate Cells have much larger pore sizes than the 15 Bar Pressure Plate Cells, and the equilibrium values in the 0 to 1 Bar range will be reached much faster. The 1 Bar Pressure Plate Cell will fit into the 1500F2 15 Bar Pressure Plate Extractor. The same Outflow Tube Connectors can be used with these Cells.

15 BAR EXTRACTOR PARTS AND ACCESSORIES

Product No.	Description
1500F2	15 Bar Pressure Plate Extractor
Accessories	
0675B0.5M2	1/2 Bar, High Flow Pressure Plate Cell
0675B01M3	1 Bar, High Flow Pressure Plate Cell
0675B03M1	3 Bar Pressure Plate Cell
0675B05M1	5 Bar Pressure Plate Cell
0675B15M1	15 Bar Pressure Plate Cell
0763G7	Safety Pressure Relief Valve
0775L60	Connecting Hose, 60 inches long (used to connect extractor to pressure control manifold)
1055K1	Right Angle Outflow Adapter Kit (includes 4 outflow adapter assemblies)
1057K1	Plug Bolt Kit (includes 5 plug bolt assemblies)
1065	Electrical Leadthrough
1080G1	PM Hinge (includes 1 each 1081 Adapter Plate)
1093F1	Soil Sample Retaining Rings, one dozen
Replacement Parts	
1060G2	Outflow Tube Assembly, with seal
Z1500-005	Brass hose fitting
Z1596K1	Clamping Bolt Set (8 assemblies)
M802X006PKG05	O-Ring Seal for 1055 Adapter, pack of 5
M802X010PKG05	O-Ring, Port Seal, pack of 5
M802X453PKG02	O-Ring, Lid Seal, pack of 2
1500-001CR	Replacement Cover
1500-002	Triangle Support
1500-003K1	Replacement Leg Set (3 legs)
Z1500-004PKG03	Plastic Spacer Kit, Set Of 3



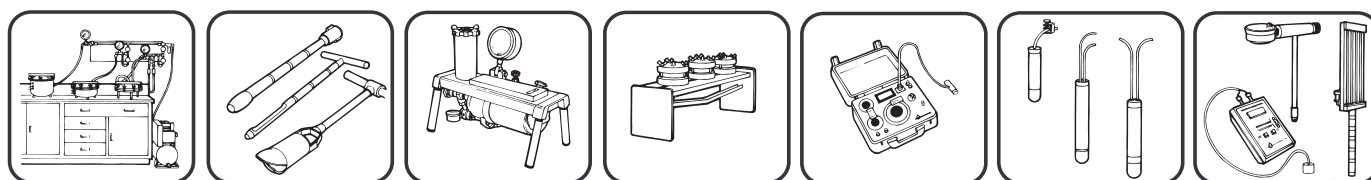

WITH DEALERS THROUGHOUT THE WORLD, YOU HAVE CONVENIENCE OF PURCHASE AND ASSURANCE OF AFTER-SALES SERVICE.

For further information, and to place orders, contact Soilmoisture Equipment Corp. or your nearest representative.

Your nearest representative: